

## Development of an Inclusive Aadhaar-Based Remote Polling Platform for Mobile Populations

Petrenko V.L.

Department of Ophthalmic Research, Odessa Vision Institute, Odessa, Ukraine

### ABSTRACT

This paper proposes a secure and easily adoptable polling platform for Indian Electoral system. This paper intends to realize the idea suggested in International Conference on “Making our elections inclusive and accessible on Jan 24<sup>th</sup> 2018. The system is based on data available from UIDAI and Election Commission. Our system works in offline and online mode. Accurate biometric information is used for authentication and authorization of voters. In this system, the user has to enroll fingerprint to register followed by verification and authorization. The finger print of voters shall be already stored in the database with the help of UIDAI. Privacy issues shall not arise since the biometric information is not handed over to any private parties. The system works in such a way that voters can cast their vote from anywhere around the world. Any attempt of corruption by multiple voting and proxy voting will be captured and reported. Online system can be used for Indian voters abroad as well as migrant employees. Offline system can be used for domestic voters. Offline system uses a Arduino UNO as controller, fingerprint scanner, GSM module, buzzer, switches and keypad. Online system works on a web platform.

**KEYWORDS:** ARDUINO UNO Biometrics ,SQL database.

---

### 1. INTRODUCTION

As we know, election is a basic process of democracy which allows citizens to showcase the opinion by selecting a candidate of their choice to govern the nation. India is spending huge amount of money to conduct nationwide elections and progressive assessments and improvements. Moreover government should ensure that voting is honest and secure. Presently used EVM's credibility is tested several times. Authentication of voters, security of voting process, protecting voted data is the main challenges of EVMs. This system doesn't allow voting rights to NRI's and migrant employees whose name in the electoral list of initial constituency has not changed to new address and is not intending to change. Therefore it is necessary to generate a secure election voting system so that all Indian citizens whether NRIs or migrant workers could take part in democracy through a strictly secure biometric authenticated platform. In this proposed system the elector has to use his fingerprint authentication to register his vote. This paper demonstrates an offline and online voting system, both based on biometric authentication.

### 2. METHODOLOGY

The proposed system implements an online and offline voting system. The online voting can be done via internet based web page and offline by using a biometric authenticated voting machine. Both the system shall be working in a highly secure environment. The proposed workings of both the systems are described here with. Initially consider that the AADHAR and voter details in electoral rolls are linked. In the present demonstration an arbitrary UID is chosen.

#### 2.1 AADHAR enabled online polling platform

We design one demo website with SQL database. Three databases are created for storing AADHAR details, Voter details and candidate details. Using that website votes can be registered.

Steps of system:

Step 1: The voter can cast vote anywhere authorized by election commission, if there is a fingerprint scanner and a computer with internet is available.

Step 2: Go to the voting compartment

Step 3: Give a fingerprint to a scanner

Step 4: system checks your fingerprint with AADHAR database's fingerprint and also checks whether they are eligible to vote.

Step 5: If the voter is eligible then it shows message “You can vote” else it shows “You can't vote because you are not eligible”

Step 6: The details of voter, electoral constituency and candidate names will be displayed. We can choose the candidate from the list of candidates.

Step 7: Then your vote is successfully registered.

Step 8: If the fingerprint doesn't match then the voter gets one more chance for authentication.

Step 9: If the voter needs to complain any corruption an external link is given to register complaint to election commission

**Online system implementation technologies**

*i. Software Requirements*

1. MySQL -It allows combination, extraction, manipulation and organization of voter's data. It is platform independent. It can be used in windows or LINUX.
- 2 HTML, CSS & PHP-It is used to design the web page
3. Web Browsers-Mozilla Firefox, Google

*ii. Hardware Requirements*

Desktop or laptop with 3.0GHZ speed processor, 40 GB hard disk capacity, Fingerprint scanner.

**2.2 AADHAR enabled offline polling platform**

The system works on ARDUINO UNO

Steps of system:

Step 1: Go to any polling station in India or Indian embassy abroad for immigrant Indian voters.

Step 2: Go to the voting compartment

Step 3: Give a fingerprint to a scanner [3]

Step 4: Micro controller checks your fingerprint with AADHAR database's fingerprint and authenticates the voter. The system matches the fingerprint of voter with the AADHAR database and displays "you can vote" on LCD display otherwise it gives and alert by a buzzer indicating proxy voting or multiple voting attempt.[4]The attempt of malpractice is reported to ECI.

Step 6: If the person is eligible to vote then it enables the switches of parties

Step 7: press the key on desired party to cast the vote.

Step 8: LCD displays "voted successfully"

Step 9: Then your vote is successfully registered

**2.2.1 Block diagram**

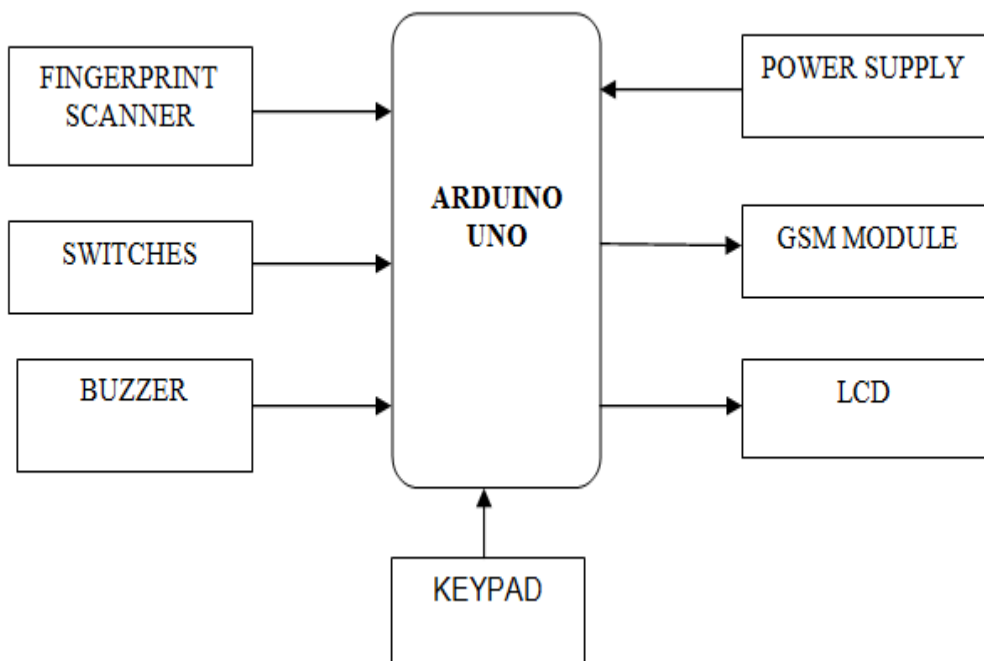

Fig 1. Block diagram

2.2.2 . System Flowchart

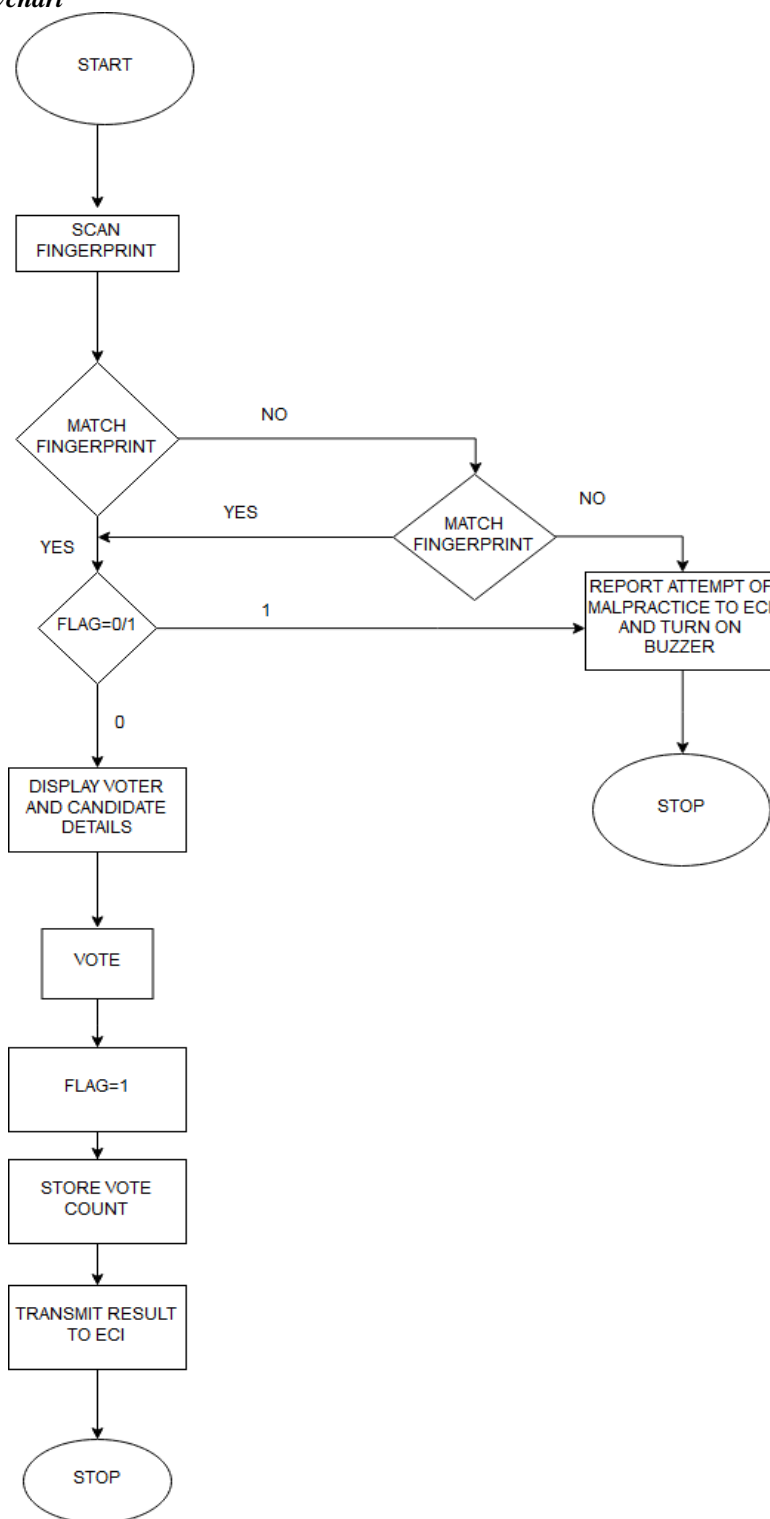

Fig.2 Flowchart

2.2.3 Components Required

a) ARDUINO UNO:

It is the microcontroller board based on ATmega 328 used in our project. It consists of 14 digital and 6 analog input/output pins.

a) FINGERPRINT SCANNER :

The scanner we used here is R305. It is an optical fingerprint scanner. The scanner module comprises of a built in controller and ADC. The ridges and valleys in the fingerprint is identified upon touching the optical scanner followed by image processing techniques

**POWER SOURCE MODULE:**

The power source module consists of transformer, rectifier, filter and voltage regulator IC 7805

b) **LCD:** 16\*2 LCD is used here. It displays voter details and voting status.

c) **BUZZER:** A buzzer or a beeper is an audio signaling device. An active buzzer is used here. It indicates any attempt of proxy voting or multiple voting.

d) **GSM MODULE**

SIM 800 GSM module is used here. It is used to send SMS to voters after successfully registering their vote as well as to Election Commission indicating any attempt of malpractice.[5]

### 3. ADVANTAGES AND DISADVANTAGES

#### *Advantages*

1. Saves time
2. Provides voting facility for NRIs and migrant employees.
3. Helps easy way of voting for physically handicapped people
4. Works in a secure environment
5. Prevents multiple and proxy voting

#### *Disadvantages*

1. Problems related to internet connectivity
2. Implementation of these systems requires legislative procedures.
3. Cyber security techniques should be implemented in a strictly secure mode otherwise threats of crackers will affect the system.

### 4. RESULTS AND DISCUSSION

As the initial phase of the project we have completed the authentication and authorization for voting. Any attempt of malpractice has been detected and reported successfully. Initially the vote flag of voters is 0. As the AADHAR number and fingerprint matches we can cast our vote and the vote flag becomes 1. As soon as the flag becomes 1 then the voter can't cast vote for second time. At the same time 1 vote is added to the corresponding candidate's vote count. And the details are send to Election Commission through GSM.

### 5. CONCLUSION

The proposed system can overcome traditional problems associated with EVMs .Online biometric based system is better and faster way of electoral setup compared to traditional system where voter needs to go to the polling booth allotted to them..In our proposed system the voter needs to go to any booth or government offices allocated for polling and cast his vote. This helps to increase the polling percentage of nation.

### 6. ACKNOWLEDGEMENTS

First of all we express our sincere thanks to KSCSTE (Kerala State Council for Science, Technology and Environment) for providing fund to realize the proposed system. We would like to express our gratitude to all the teaching and non-teaching staffs of College of Engineering, Karunagappally for their whole hearted support and for providing us with the necessary infrastructure. We also like to express my sincere thanks to Dr.Jaya.V.L, The Principal of the college for her kind support for the progress of our project work. Special thanks to the Head of The Electronics and Communication Department, Dr. Gopakumar.C for all the proper guidance and encouragement. We are grateful to our friends and parents for their valuable support and motivation.

### REFERENCES.

- [1] Himanshu Aggarwal,G.N pandey,Online Voting System for India based on AADHAR ID, 2013 Eleventh International Conference on ICT and Knowledge Engineering.
- [2] Patchav Vamsikrishna Sonti Dinesh Kumar Dinesh Bommisetty Akshat Tyagi. Raspberry pi voting system,A reliable technology for transparency in democracy ,IEEE International Conference on Advances in Electronics, Communication and Computer Technology (ICAECCT),201
- [3] R. Murali Prasad, Polaiah Bojja and Madhu Nakirekanti, AADHAR based Electronic Voting Machine using Arduino, International Journal of Computer Applications (0975 – 8887) Volume 145 – No.12, July 2016.
- [4] Hari K. Prasad et.al. Security Analysis of India's Electronic Voting Machines, International Journal of Engineering Science & . Advanced Technology, ISSN: 2250-3676, Volume-4, Issue-2, 237-240.